

Examples of de-embedding, passivity and data fitting in RF design

Jussi Rahola, Optenni Ltd
March 10, 2026

Contributions from Jaakko Juntunen, Optenni Ltd



Contents

- De-embedding
 - Changing the reference plane in antenna impedance measurements
 - Removing the effect of measurement jigs in component measurements
- Data fitting
 - Corrections of reference plane measurements
 - Finding equivalent circuit models
- Passivity checks
 - Checking the quality of measured component models

De-embedding

- De-embedding: removing the measurements affected by the fixture leaving only the behavior of the device under test.
- Techniques
 - VNA: port extension
 - Removing cable delay and cable losses mathematically
 - Negating an S parameter block
 - Data fitting
 - On-board calibration or custom calibration kits



On-board calibration for matching

- The reference plane should be at the first matching component
- Instead of VNA calibration, construct a custom calibration standard at the matching circuit location

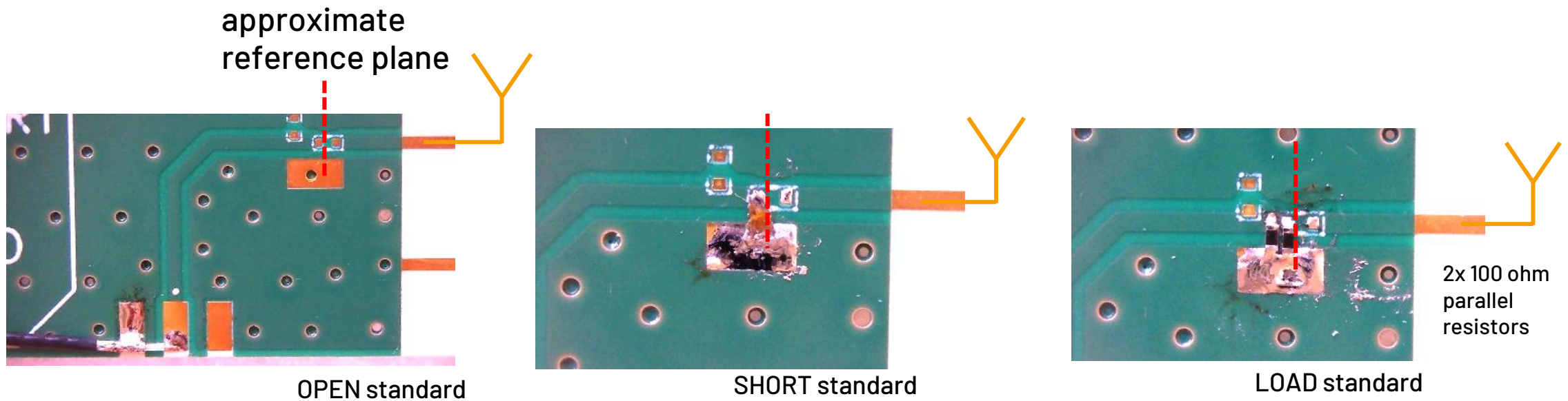

Design procedure

- Measure the unmatched antenna
- Synthesize the matching circuit
- Build the prototype
- Measure the prototype
- Correct and iterate if needed

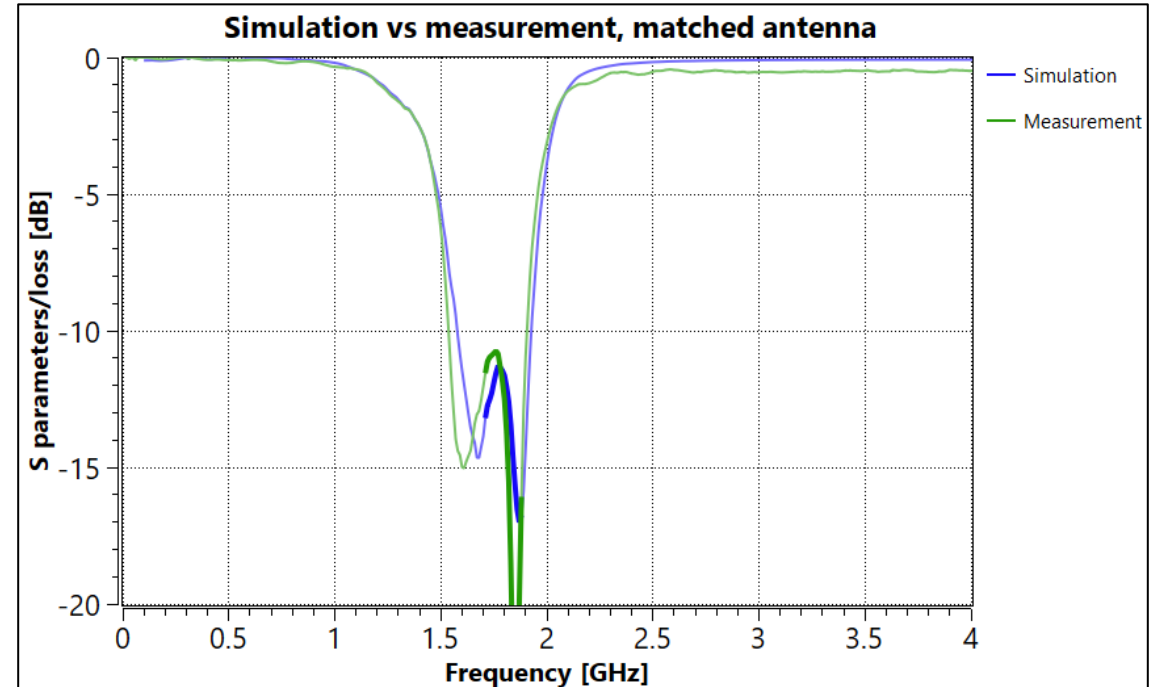
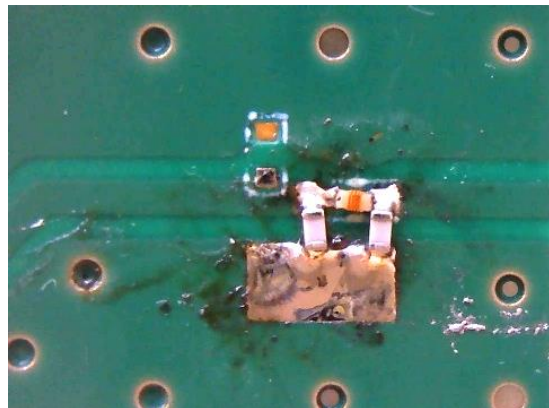

Fine tuning and model fitting

- Insert four optimizable microstrip segments around the components

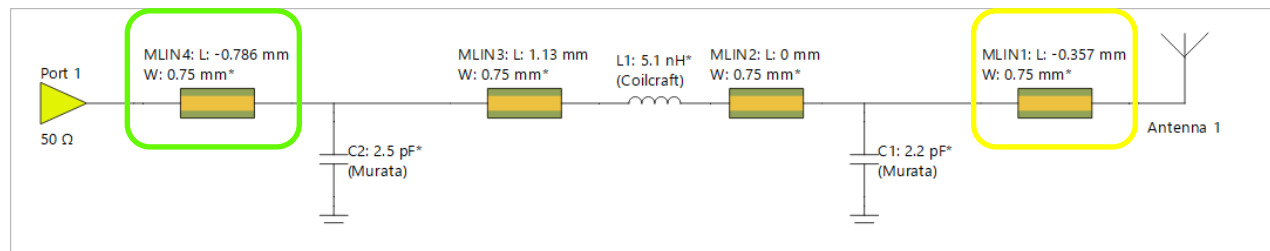

- The first and last segments change the reference plane
- The optimization target is to minimize the difference between the measurement and simulation over a broad frequency range

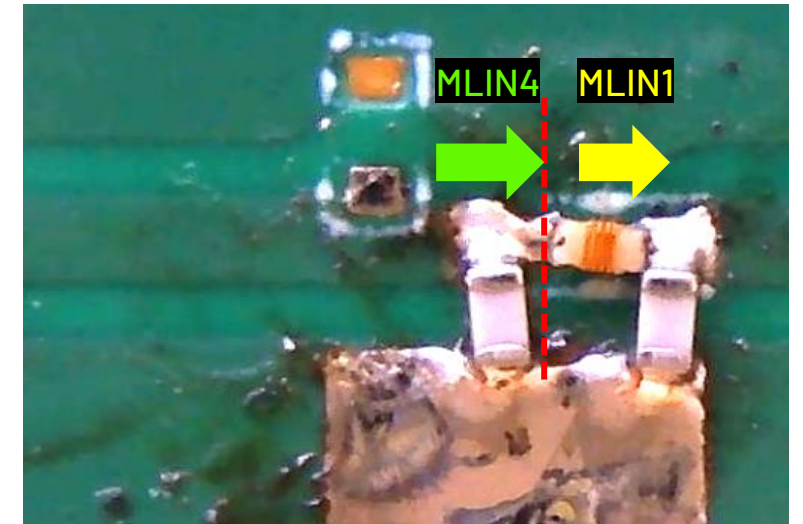

Effect of corrections

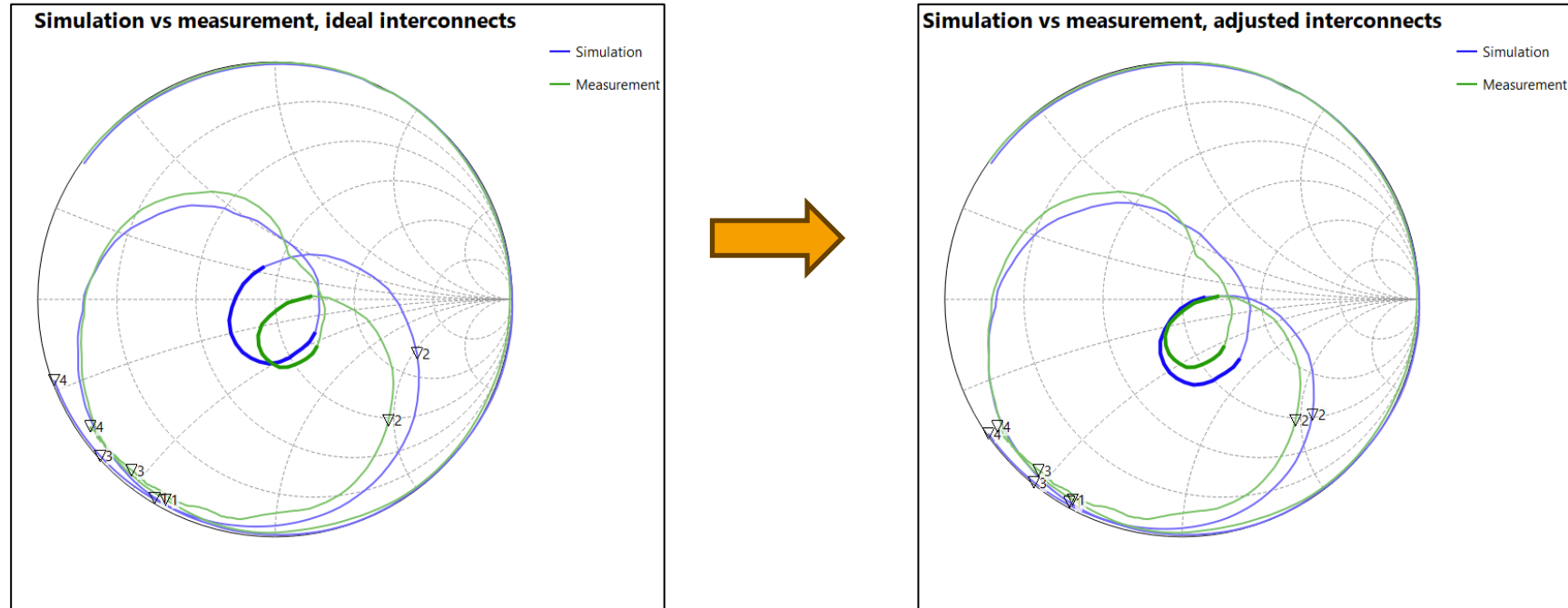

- If needed, the component values can now be re-optimized

Model fitting to find reference plane

- Measurement of open circuit using a calibrated pigtail probe
- How to transfer the reference plane to the matching circuit location?

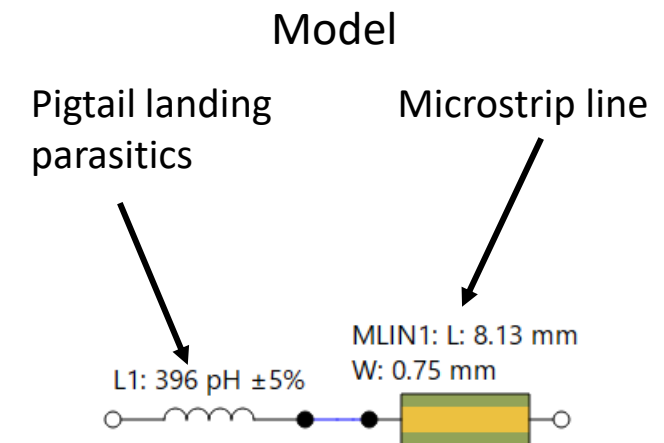
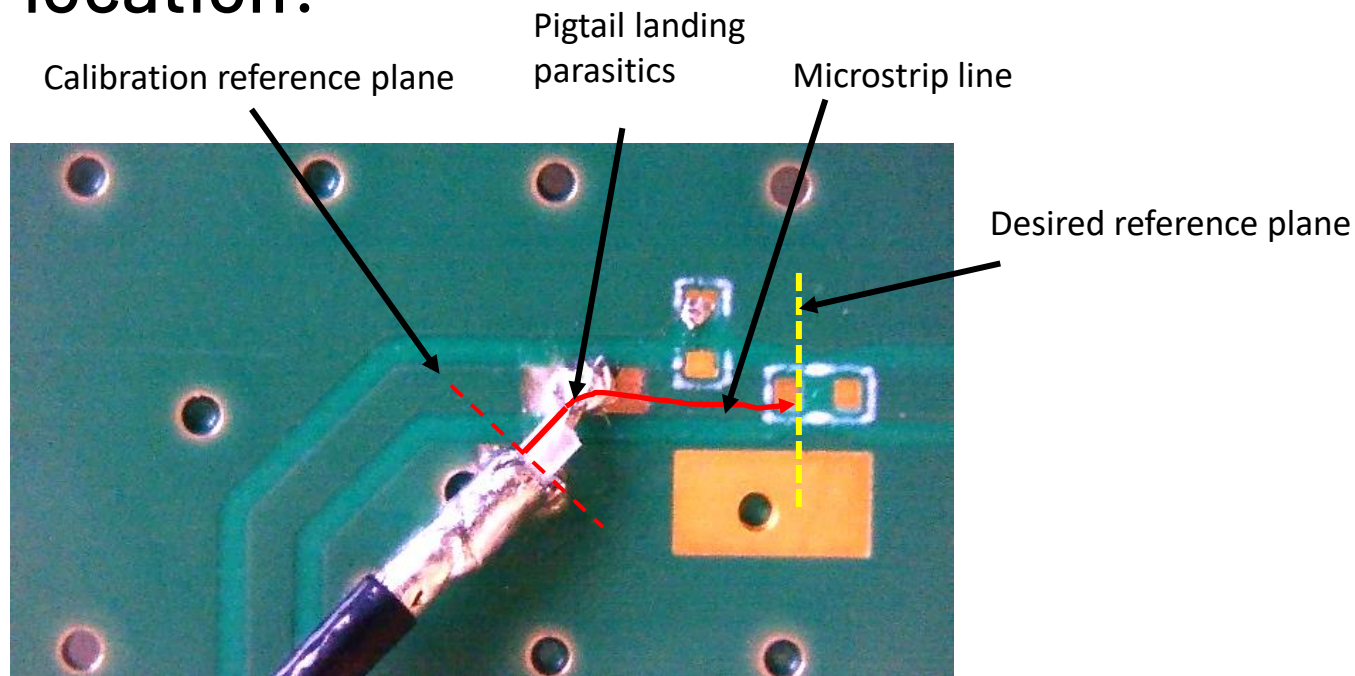

Model fitting approaches

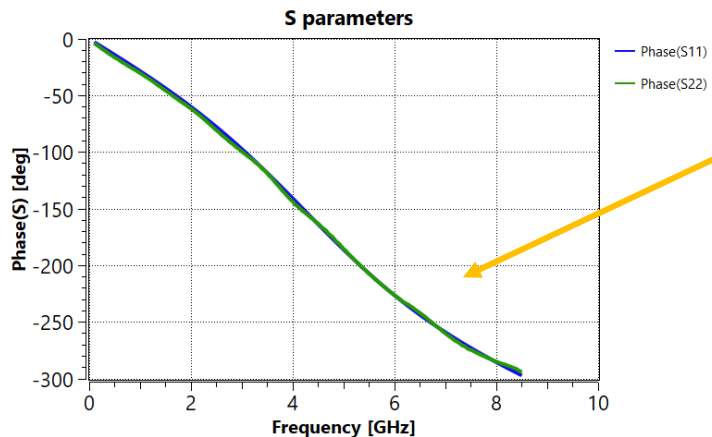
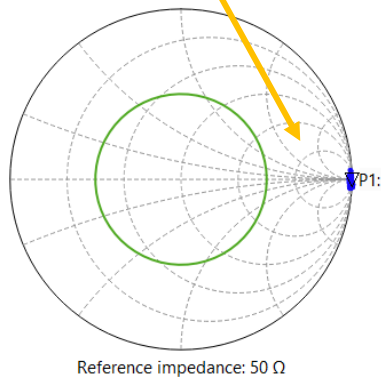
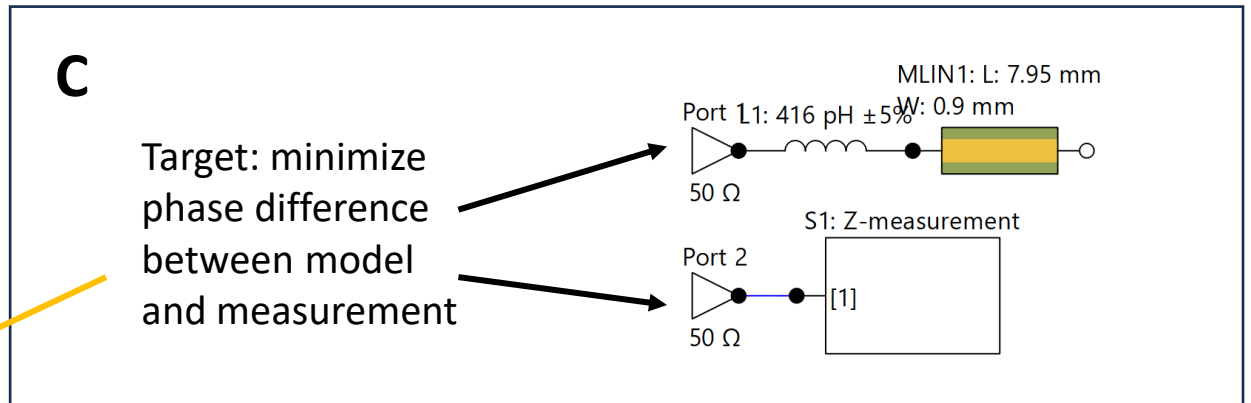
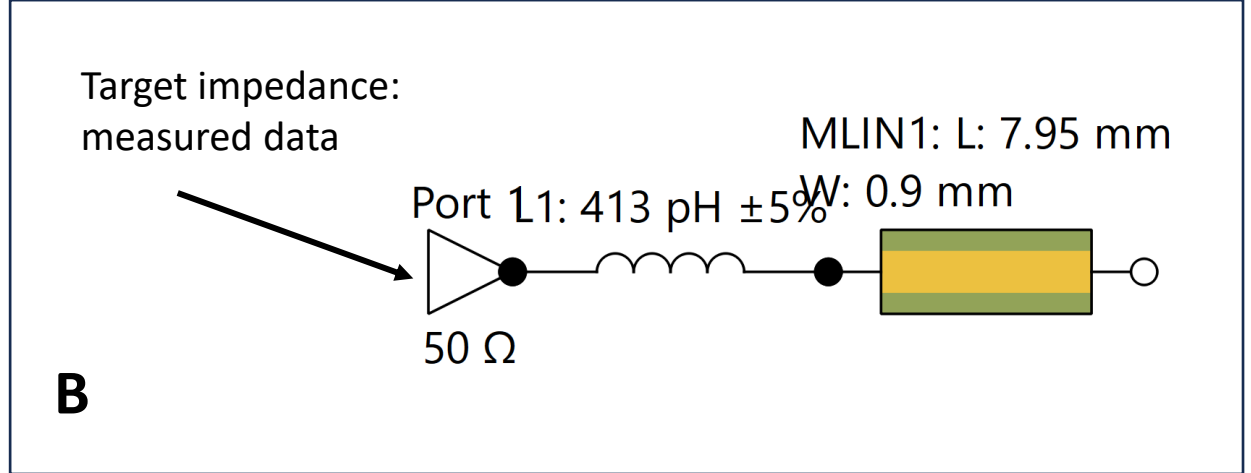
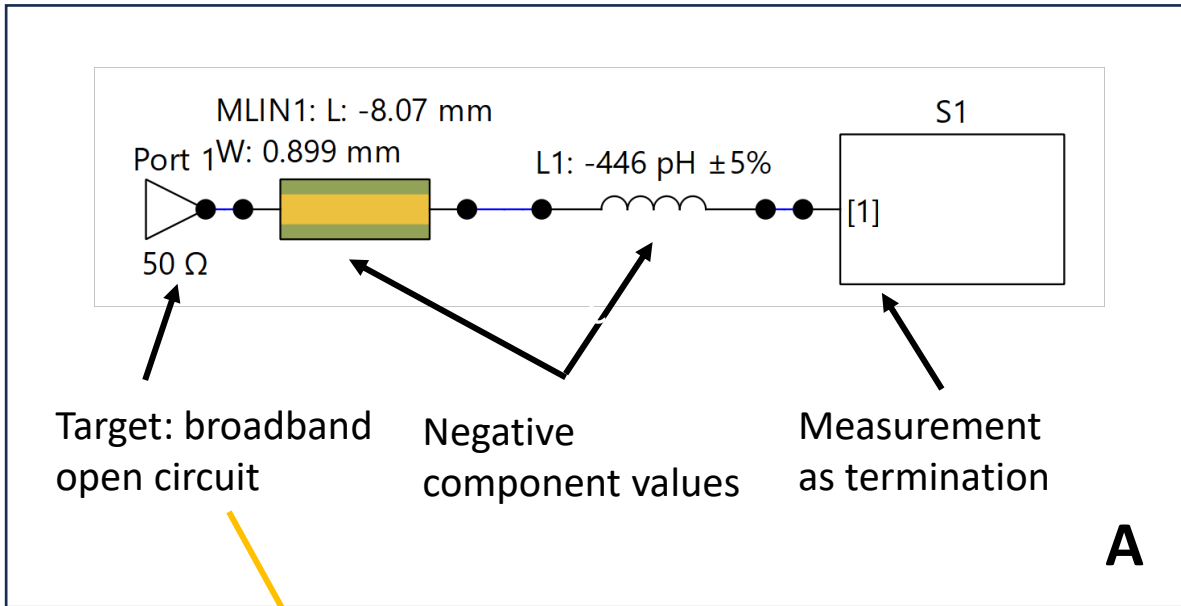

Data fitting of component models

- Inductor equivalent circuit without pads

Equivalent circuit fitted to a 4 nH inductor from Coilcraft

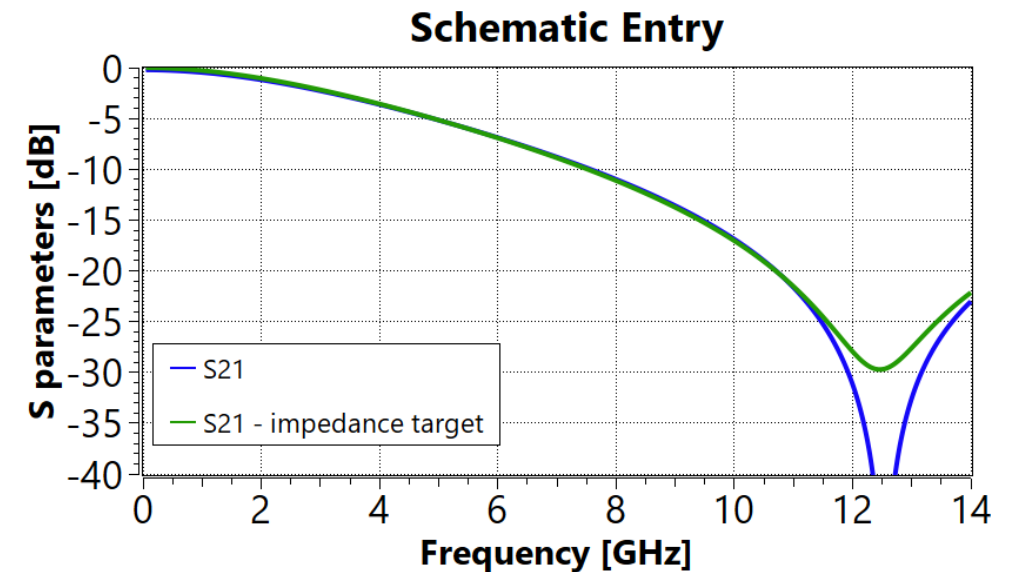
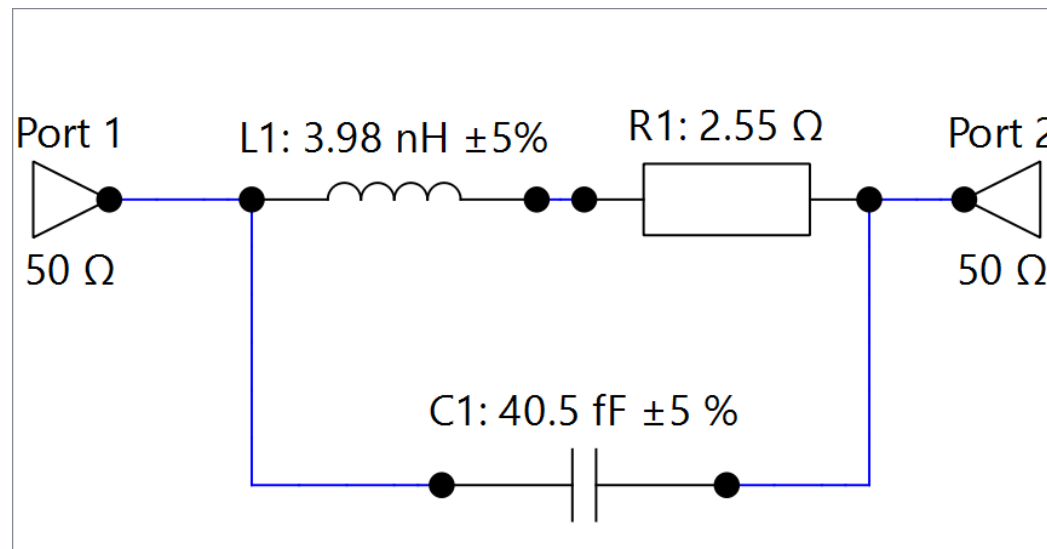

With pads - first attempt: capacitors

4.7 nH inductor from Johanson

Setup: same cap value on both sides

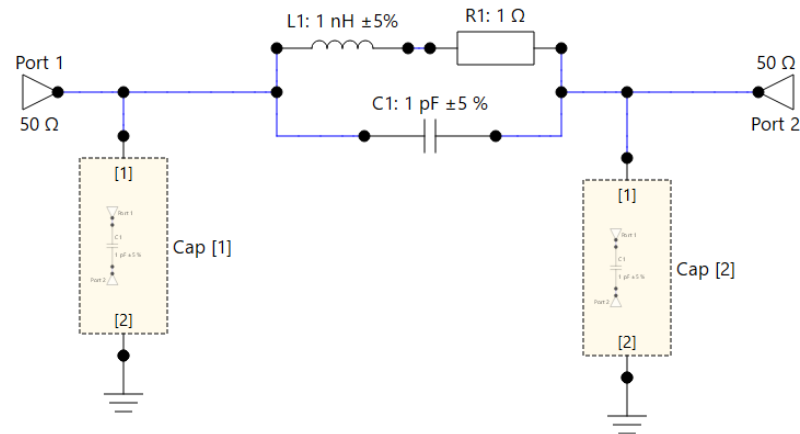

Result: 36 fF capacitors

Reasonable agreement

Capacitor pads

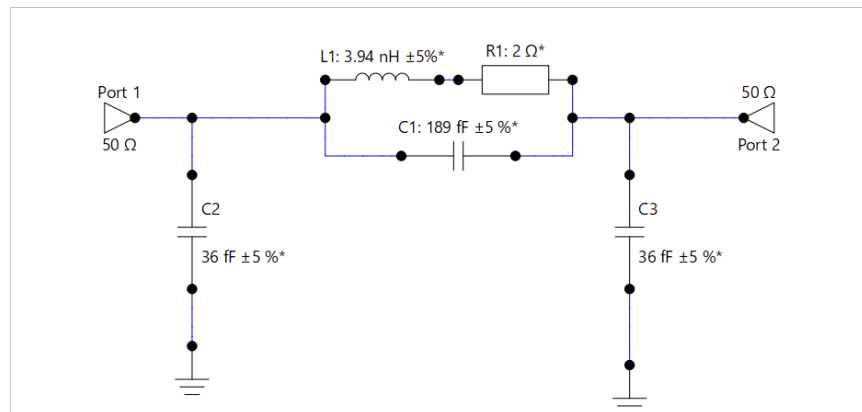
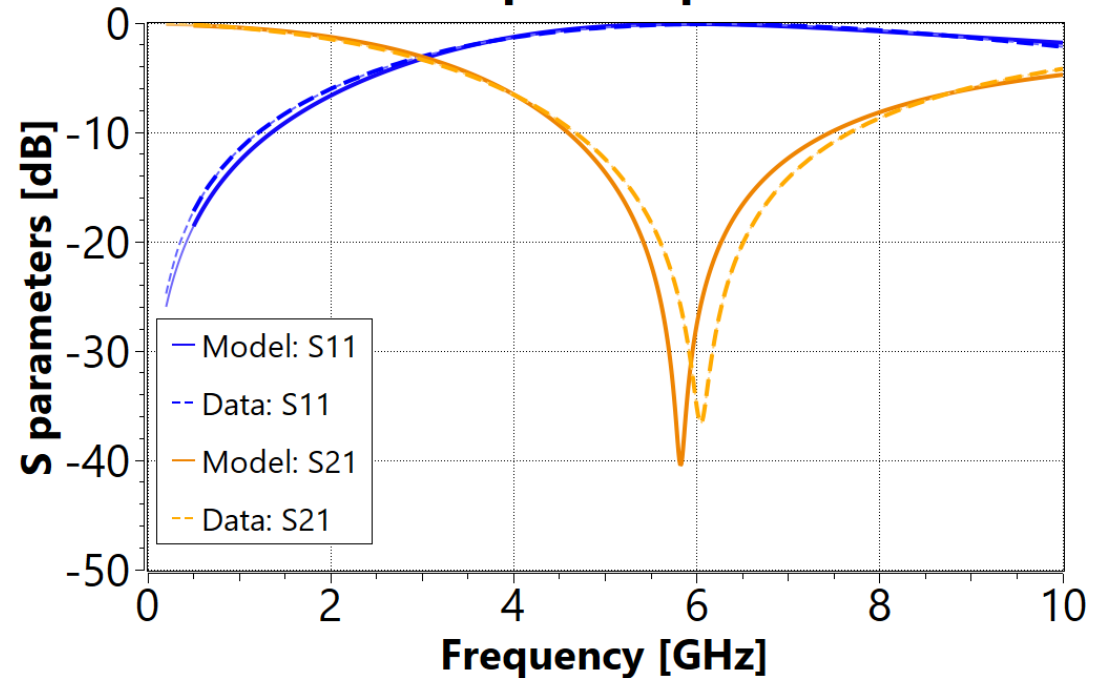

With pads - second attempt: microstrips

4.7 nH inductor from Johanson

Setup: similar microstrips on both sides

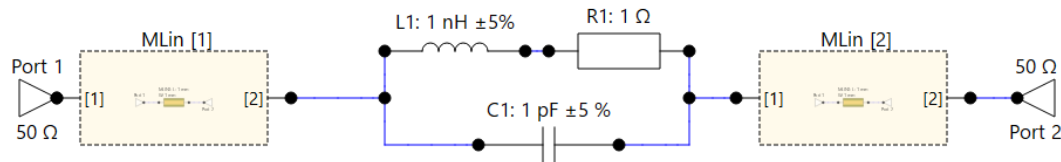

Result: 0.4 mm² microstrip

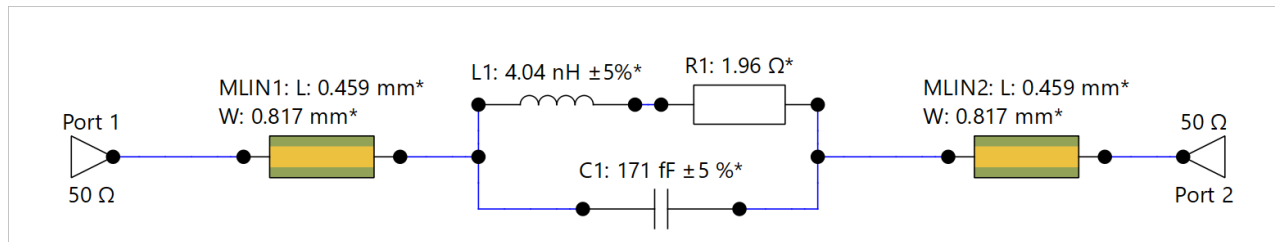

Excellent agreement

Microstrip pads

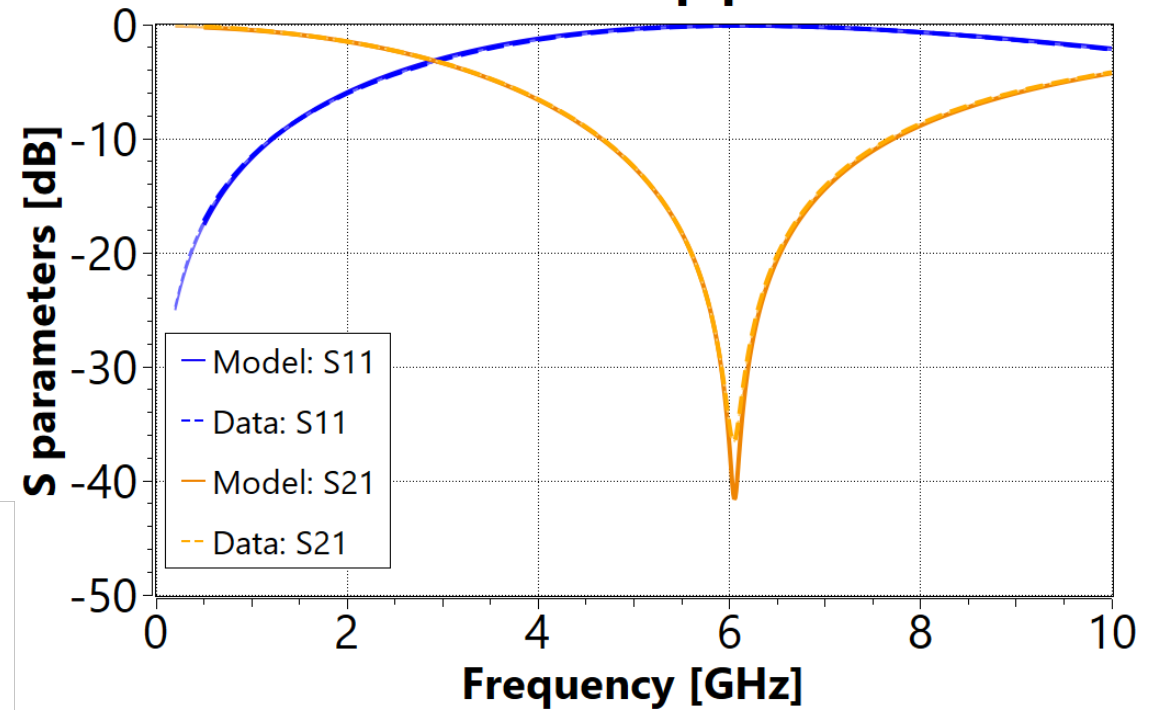

Multi-port de-embedding

- When characterizing components, e.g. inductors, capacitors and switches, the effect of measurement fixtures needs to be removed
- If done incorrectly, the data may become non-passive
- Passivity check of S parameters:
 - Eigenvalues of $I-S^*S$ are all non-negative
 - Eigenvalues of S^*S are not larger than unity

Non-passive switch model

- Switch is non-passive below 1 GHz

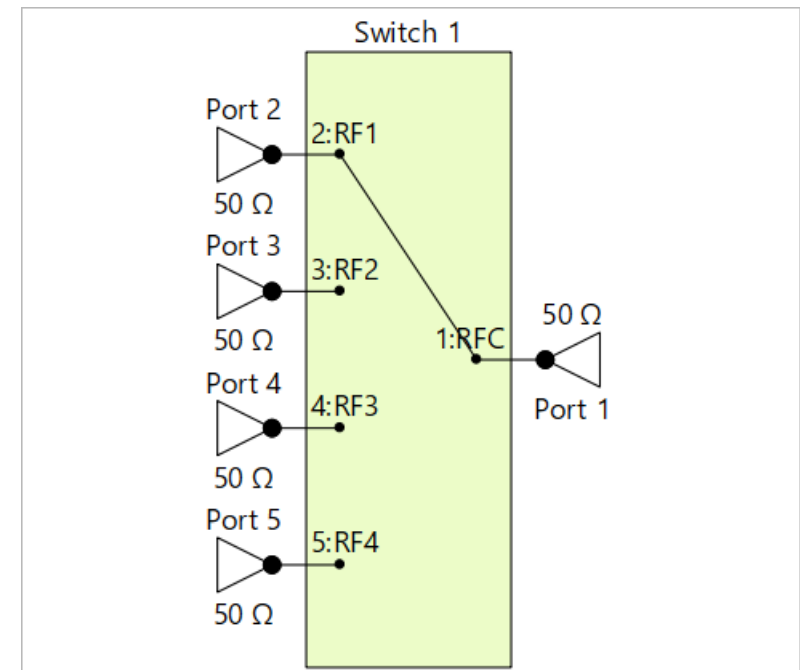
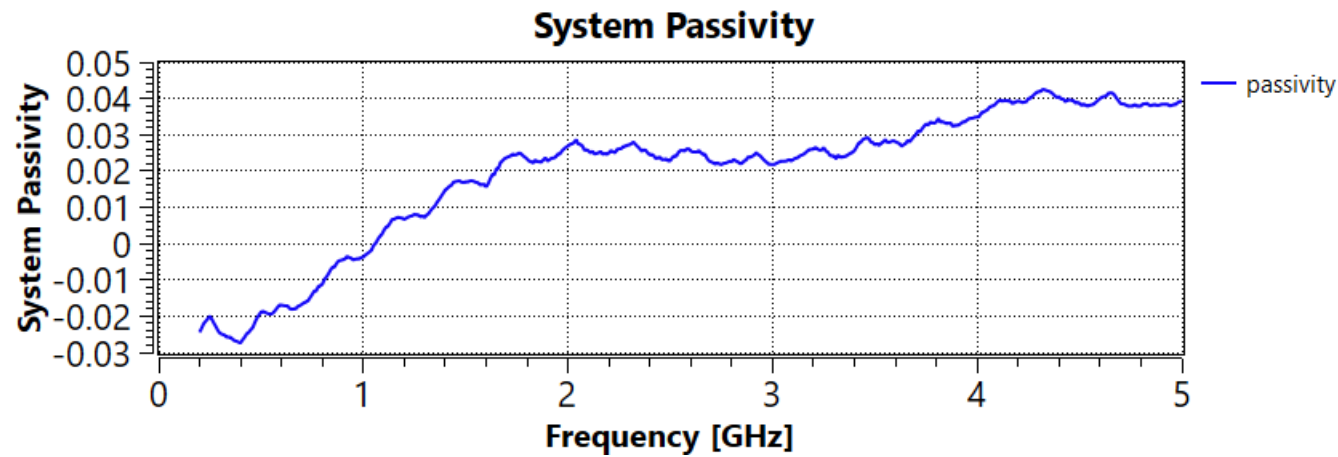

Maximizing S12 over the switch

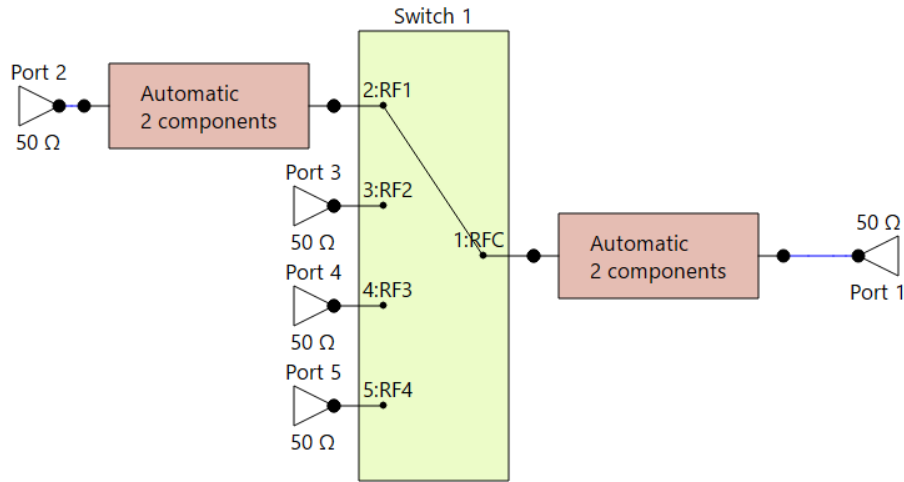

Schematic Entry

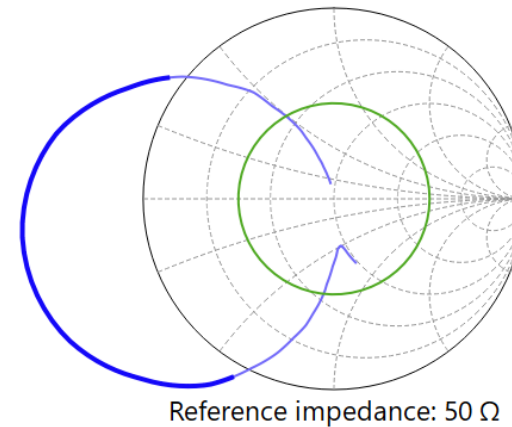
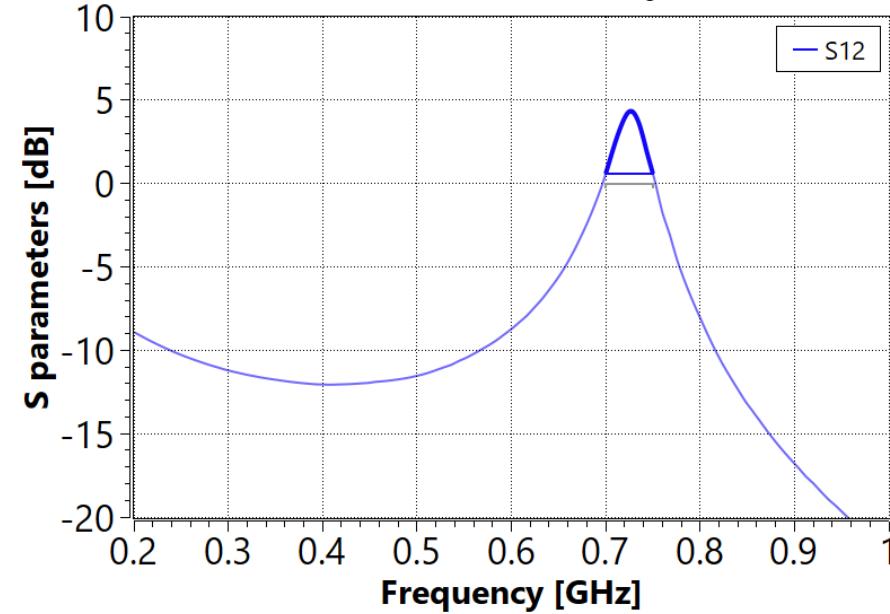

Conclusions

- When designing matching circuits, it is important to measure the input impedance at the correct reference plane
- Good results can be obtained with on-board calibration standards and data fitting
- For two-port components, data fitting identifies equivalent component models and shows the amount of ground coupling
- When measuring components, the quality of the results must be evaluated by checking symmetry and passivity of the results



www.optenni.com